

FIRE-POWER
15 KW THREE PHASE
SELF-CONTAINED HYDRAULICALLY
DRIVEN ELECTRIC MOBILE POWER
GENERATOR PACKAGE

INSTRUCTION MANUAL

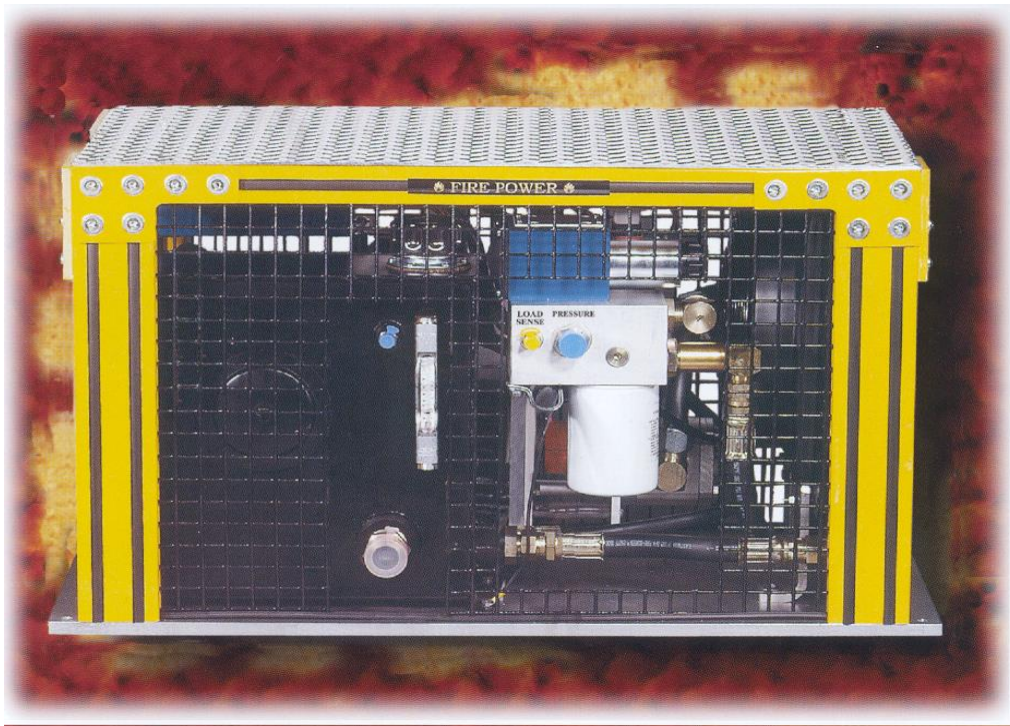

ANOTHER FINE PRODUCT BY
FABCO GENERATORS INC.

CHESTER, NY 10918

VOICE (845)-469-9151

FAX (845)-469-7871

WEB SITE: www.fabcopower.com

e-mail: mail@fabcopower.com

CAUTION

DO NOT MOUNT OR ATTACH ANY EQUIPMENT ON TOP OR SIDES OF OUR GENERATOR ENCLOSURE.

DO NOT INSTALL RADIO ANTENNAS WITHIN A MINIMUM OF EIGHT FEET FROM OUR GENERATOR SYSTEM. WE RECOMMEND TEN FEET FROM OUR GENERATOR.

LOW AND HIGH BAND RADIO FREQUENCIES TRANSMITTED FROM ANTENNAS LOCATED AT A DISTANCE OF UNDER EIGHT FEET FROM OUR GENERATOR CONTROL CAN INTERFERE WITH THE GENERATORS OPERATION.

Fire Power

GENERAL SAFETY PRECAUTIONS

GENERATOR VOLTAGE CAN BE DEADLY

GENERATOR ELECTRICAL CONNECTIONS MUST BE MADE BY A TRAINED ELECTRICIAN IN ACCORDANCE WITH APPLICABLE CODES.

USE EXTREME CAUTION WHEN WORKING ON LIVE ELECTRICAL EQUIPMENT. REMOVE JEWELRY, MAKE SURE HANDS, CLOTHING AND SHOES ARE DRY AND USE TOOLS WITH INSULATING HANDLES.

WET CELL BATTERIES CAN CAUSE SEVERE INJURY

THEY CAN EXPLODE! DO NOT SMOKE WHILE WORKING NEAR WET CELL BATTERIES. WEAR SAFETY GLASSES.

BATTERY ACID CAN CAUSE BLINDNESS AND SEVERE SKIN DAMAGE. BATTERY GASSES CAN CAUSE EYE AND LUNG DAMAGE.

TO REDUCE SPARKS WHEN DISCONNECTING OR RECONNECTION BATTERY CABLES ALWAYS DISCONNECT THE NEGATIVE (-) CABLE FIRST AND CONNECT IT LAST.

MOVING PARTS CAN BE DEADLY

KEEP HANDS AWAY FROM MOVING PARTS. DO NOT WEAR LOOSE CLOTHING OR JEWELRY NEAR MOVING PARTS SUCH AS FANS, PTO'S, BELTS OR ANY OTHER MOVING PARTS.

KEEP ALL GUARDS IN PLACE OVER BELTS, COUPLINGS, PULLEYS AND ALL OTHER MOVING PARTS.

HIGH PRESSURE HYDRAULIC FLUID CAN CAUSE SEVERE INJURY

ALWAYS SHUT DOWN THE PRIME MOVER OF THE HYDRAULIC PUMP BEFORE WORKING ON FITTINGS.

HIGH PRESSURE SPRAY FROM A LEAK OR BROKEN HOSE CAN CAUSE BLINDNESS, WEAR SAFETY GLASSES. IF HOT, HIGH PRESSURE HYDRAULIC FLUID PENETRATES THE SKIN IT COULD CAUSE BLOOD POISONING. GET PROPER MEDICAL ATTENTION ASAP.

FIRE-POWER OWNERS MANUAL

TABLE OF CONTENTS

SECTION # 1 INTRODUCTION
SPECIFICATIONS AND
WARRANTY

SECTION # 2 HYDRAULIC PUMP, DRAWINGS,
FITTINGS, HOSES AND
PRESSURE REQUIREMENTS

SECTION # 3 AC AND DC ELECTRICAL HOOK-UP
AND WIRING DIAGRAMS

SECTION # 4 MECHANICAL DRAWINGS, MOUNTING TEMPLATE
INSTALLATION AND START-UP

SECTION # 5 MAINTENANCE, TROUBLE SHOOTING,
MAINTENANCE LOG & TEST REPORTS

SECTION # 1

**INTRODUCTION
SPECIFICATIONS
WARRANTY**

INTRODUCTION

FIRE-POWER SELF-CONTAINED HYDRAULICALLY DRIVEN, ELECTRONICALLY CONTROLLED, ELECTRIC POWER GENERATOR

The ***FIRE-POWER system*** was developed for the fire and rescue industry because of the need for safe, reliable and precise electric power. This is essential as electric powered rescue equipment is becoming more sophisticated. The ***FIRE-POWER system*** is reliable, safe, maintenance free, quiet and environmentally friendly.

Fire engines idle speed is about 750 RPM and when pumping water the idle is electrically or mechanically set at between 1000 to 2000 RPM. The ***FIRE-POWER system*** can deliver continuous, precisely regulated electric power at engine speeds that vary from 750 RPM to over 2,200 RPM, or from zero to over fifty five miles per hour, on any vehicle with a power take off (PTO) on the transmission. The ***FIRE-POWER system*** has many other applications that specify continuous, precisely regulated electric portable power.

The ***FIRE-POWER system*** is a completely self-contained vehicle mounted electric power generating package that produces and maintains a constant 120/240 volts at 60 HZ. The system is easy to install, (it takes the guesswork out of the installation), follow the simple step by step instructions contained on the following pages, (***NO ADJUSTMENTS TO THE SYSTEM ARE REQUIRED***).

The ***FIRE-POWER system*** includes a factory tested and calibrated PTO mounted hydraulic pump, panel mounted start-stop switch, voltage regulator, oil tank, temperature-controlled oil cooler and a unique Electro-Mechanical speed and frequency control network, all in one complete compact package. The unique Electro-Mechanical control system incorporates an automatic soft start from zero to 60 HZ in 20 seconds, and a soft stop from 60 HZ to zero in 10 seconds. This protects all of the component parts in the system from damage due to high torque and mechanical shock in non-accelerated starts and non-decelerated stops. Soft starts and stops increases the life of all the systems component parts. The acceleration and deceleration is essential in extreme hot or cold weather operation.

The ***FIRE POWER system*** comes complete with a panel mounted digital meter displaying voltage, frequency, double line ammeter, elapsed time, oil temperature and a high oil temp alarm. The frequency and voltage regulation is constant with no deviation from zero percent to 100% load, or from engine idle to 2,200 RPM. The ***FIRE POWER system*** far exceeds the NFPA specifications.

The ***FIRE POWER system*** can run the most sophisticated electric powered devices including high tech electronic computers, communication, and rescue and test equipment.

**FIRE POWER SELF CONTAINED HYDRAULIC DRIVEN
GENERATOR SAMPLE SPEC
7.5, 10, 12, 14, 20KW SINGLE PHASE MODELS
AND 15 KW THREE PHASE MODELS**

- 1. THE FABCO POWER SELF-CONTAINED GENERATOR MEETS ALL THE REQUIREMENTS DEFINED IN NFPA SPEC, 1901 CHAPTER 19-14.5.**
- 2. THE PRIME MOVER FOR THE HYDRAULIC PUMP SUPPLIED IS PTO DRIVEN FROM THE TRUCKS TRANSMISSION.**
- 3. THE GENERATOR SYSTEM IS SUPPLIED WITH THE FOLLOWING. A FACTORY CALIBRATED PISTON HYDRAULIC LOAD SENSING PUMP. A BASE CONTAINING, OIL RESERVOIR WITH AN OIL TEMPERATURE AND LEVEL INDICATOR. ALL HYDRAULIC FITTINGS AND HOSES ARE SAE AND JIC TO AVOID LEAKS. HYDRAULIC MOTOR, PRE WIRED GENERATOR WITH 15 FOOT OF WATERTIGHT POWER CABLE. OIL COOLER WITH 12 VDC FAN, ELECTRONIC HYDRAULIC CONTROL VALVE, ELECTRONIC VOLTAGE AND FREQUENCY CONTROLLER WITH A 20 SECOND START RAMP FROM 0 TO 60HZ. REMOTE START STOP SWITCH WITH 15 FOOT OF CABLE, DIGITAL REMOTELY MOUNTED FREQUENCY, VOLT, TWO LINE AMP, ELAPSED TIME, OIL TEMPERATURE DISPLAY INCLUDING A HIGH OIL TEMPERATURE ALARM.**
- 4. NO START-UP OR OPERATIONAL ADJUSTMENTS ARE REQUIRED.**

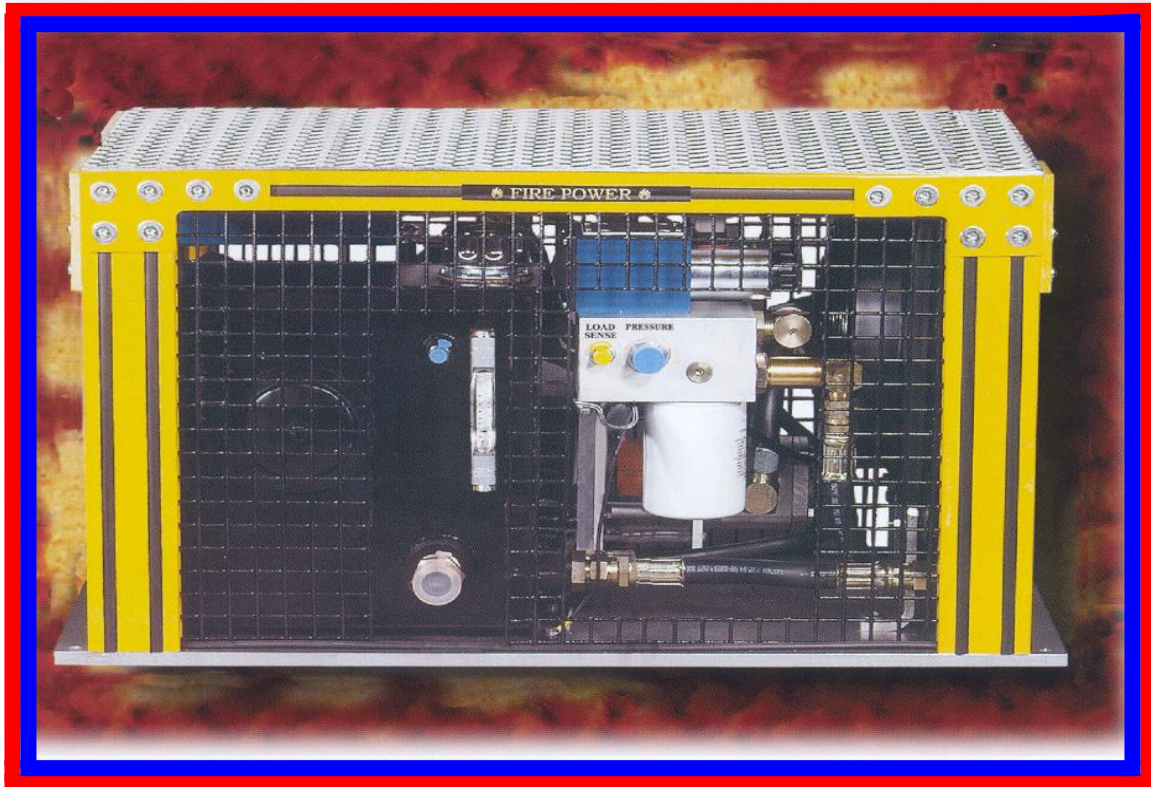

***FABCO POWER'S 15 KW THREE PHASE HYDRAULIC
DRIVEN GENERATOR SELF CONTAINED SYSTEM***
LINE-TO-LINE VOLTAGE IS 218 VOLTS AVERAGE AT 40 AMPS PER PHASE

THE THREE-PHASE FIRE POWER system (PATENT #6394206) is completely self contained and easy to install, ***AND NEVER NEEDS ANY ADJUSTMENTS.*** Unlike any other hydraulic generator package on the market today this system is ahead of its time. It is like having ***THREE 5 KW 125/218 VOLT SINGLE PHASE. LINE-TO-LINE VOLTAGE IS 218 VOLTS AVERAGE AT 40 AMPS PER PHASE.***

The THREE PHASE 15 KW FIRE POWER is a complete system, including a 71cc hydraulic pump, pre-wired generator, voltage regulator, oil tank & cooler, electronic speed and frequency control soft start from zero to 60 HZ in 30 seconds. The ***THREE PHASE FIRE POWER system*** comes complete with a digital meter displaying voltage, frequency, ammeter, elapsed time, oil temperature display and alarm.

The frequency regulation is perfect with no deviation at all, from engine idle to 2400 RPM. The ***FIRE POWER system*** far exceeds the NFPA specifications. Keeping the sine wave stable and the frequency regulation perfect accomplishes the precise power output. The ***THREE-PHASE FIRE POWER*** generating system incorporates radio frequency interference (RFI) suppression filters and can run the most sophisticated electronic equipment.

FIRE POWER LIMITED LIFETIME WARRANTY
FABCO GENERATORS INC. WARRANTY TERMS

EACH FIRE-POWER SELF CONTAINED HYDRAULIC GENERATOR SYSTEM IS WARRANTED TO THE ORIGINAL OWNER TO BE FREE FROM DEFECTS IN MATERIAL OR WORKMANSHIP UNDER NORMAL USE AND SERVICE FOR LIFE.

The warranty is valid only on the original equipment the FIRE-POWER SYSTEM is initially installed on, (FROM THE DATE OF THE INSTALLATION).

This warranty will be void on any component parts that show evidence of misapplications, improper installation, abuse, lack of ventilation, improper maintenance, contaminants in the hydraulics, or any alterations from Fabco's Original design. This warranty will be void on any and all component parts that are damaged as a result accidents or acts of God.

This warranty is only applicable to all component parts supplied by Fabco Generators inc. This warranty will be void if damage is due to the FIRE-POWER SYSTEM as a result of broken external hoses or fittings that can cause leaks and damage the hydraulic pump, motor or any other component parts. This warranty will be void if any external electrical connections are improper causing shorts that damage any electrical components in the FIRE-POWER electrical system.

No other company, corporation or person is authorized to give any other warranties or to assume any other liabilities on behalf of FABCO GENERATORS INC. Liability for any defective component parts on the FIRE-POWER system is limited to repair or replacement by FABCO GENERATORS INC. at its option.

Under no circumstances will FABCO GENERATORS INC. be responsible for accidental, incidental or consequential damages arising from, or in conjunction with the use of any FIRE-POWER electric generator system.

Warranty Card must be completed and returned within 90 days of installation or warranty may be void.

WARRANTY PROCEDURE

WARRANTY PAPER TRAIL:

- 1. CALL FABCO POWER WITH UNIT SERIAL NUMBER.**
- 2. GIVE FABCO THE OPPORTUNITY TO TROUBLE SHOOT OVER THE PHONE.**
- 3. IF FABCO CAN'T FIX IT OVER THE PHONE, FABCO WILL SEND A FIELD SERVICE PERSON OR ISSUE A RETURN GOODS AUTHORIZATION NUMBER (RGA) TO SHIP THE UNIT BACK TO FABCO, FREIGHT PRE-PAID.**
- 4. FABCO WILL THEN INSPECT THE UNIT OR PART AND DECIDE WHETHER IT IS UNDER WARRANTY OR NOT**
- 5. IF THE PROBLEM IS NOT A WARRANTY ITEM THEN FABCO WILL BILL YOU FOR SHIPPING AND REPAIR CHARGES. FABCO WILL INCLUDE A REPORT DETAILING WHAT WAS FOUND, AND HOW TO PREVENT IT FROM HAPPENING IN THE FUTURE.**

SECTION # 2

HYDRAULIC PUMP, DRAWINGS, FITTINGS, HOSE SIZES AND PRESSURE REQUIREMENTS

Variable displacement pump A10VO, Series 31

Unit dimensions, size 71

Service ports at rear, no through drive; model 91 N00 without considering control

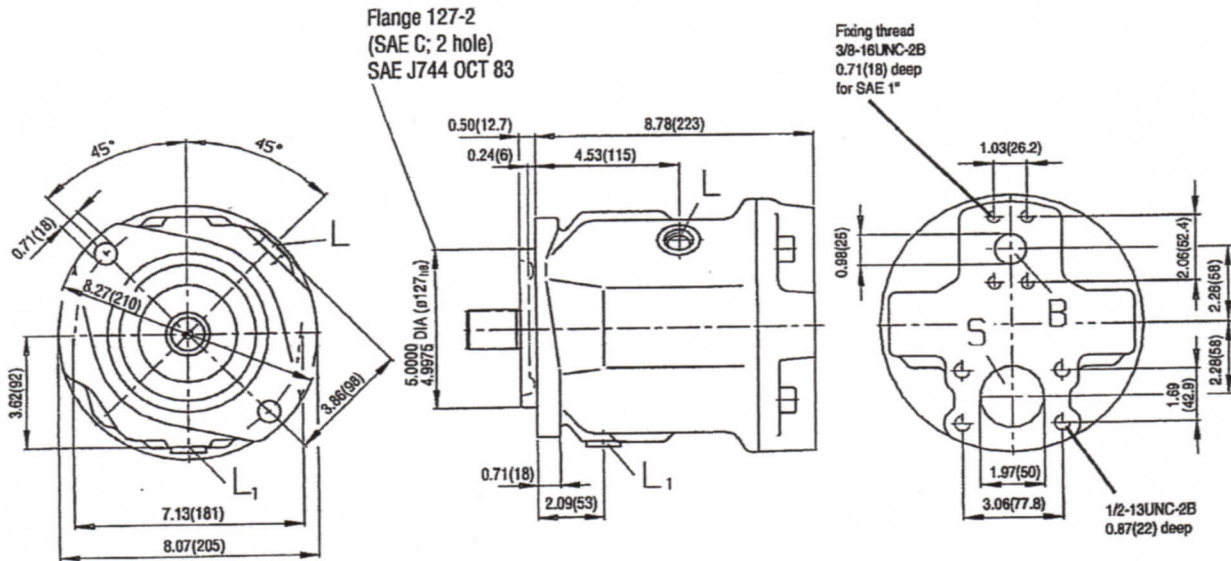

RIGHT ROTATION

Drive shaft S
32-4; (SAE C)
SAE J744 OCT 83

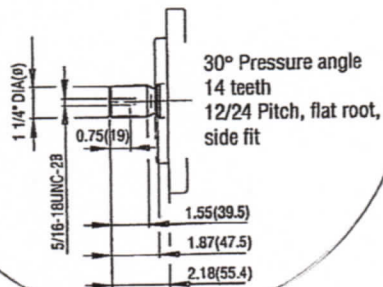

Drive shaft R
32-4; (SAE C) Modified
SAE J744 OCT 83.

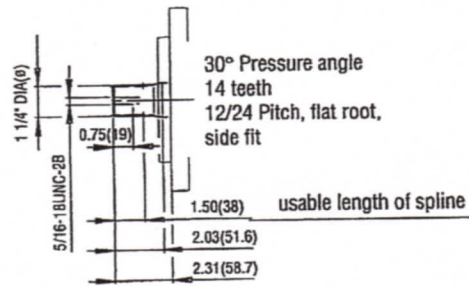

CAUTION!!

Pressure port B with one port size option!
1.) Port size 1" SAE, standard pressure series (Code 61) 5000 psi,
for pressures higher 3600 psi (250 bar)

For both, operating pressures higher 3600 psi (250 bar) and new applications 1" SAE pressure flange must be used!

Port connections

B	Pressure port	1" SAE	(standard pressure series)
S	Suction port	2" SAE	(standard pressure series)
L	Case drain port	7/8-14 UNF-2B	
L ₁	Case drain port	7/8-14 UNF-2B	(sealed in factory)

TECHNICAL INFORMATION REQUIRED TO KNOW BEFORE ORDERING A POWER TAKE OFF (PTO), FOR A FABCO POWER, 12 AND 14KW SINGLE PHASE OR 15KW THREE PHASE FIRE-POWER SELF CONTAINED GENERATOR SYSTEM

1. DOES THE TRUCK EXIST OR IS IT BEING SPECKED?
2. LOCATE THE TRANSMISSIONS MAKE AND MODEL NUMBER IF AVAILABLE.
3. CONTACT THE TRUCK BODY BUILDER OR THE TRANSMISSION MANUFACTURER FOR AN EXISTING OR A TRUCK BEING SPECKED.
4. SEND THEM THE SPECIFICATIONS FOR OUR 71 CC PUMP USED ON OUR 12 AND 14 KW GENERATORS. (FABCO POWER WILL SUPPLY YOU WITH THE COMPLETE PUMP SPECK SHEET INCLUDING THE HORSE POWER AND TORQUE REQUIREMENT CURVES).
5. THE ROTATION OF OUR STOCK PUMP IS CLOCK WISE OR (RR) THE PTO SHOULD BE COUNTER CLOCK WISE OR (LR). IN SOME CASES THE PTO ROTATION IS (CW) IF SO A (LR) PUMP MUST BE USED.
6. DOES THE GENERATOR HAVE TO DELIVER FULL POWER (KW) AT IDLE, IF SO WHAT IS THE ENGINES IDLE SPEED? IF NOT USE THE ENGINES FAST IDLE SPEED TO CALCULATE THE PUMPS SPEED.
7. WHAT IS THE RATIO OF THE PTO TO ENGINE SPEED? WE RECOMMEND A 1.3 TO ONE.
8. EXAMPLE ENGINE IDLE = 750 RPM X 1.3 = A PTO SPEED OF 975 RPM. 975 RPM IS THE MINIMUM SPEED OF OUR 71cc PUMP REQUIRED TO DELIVER FULL KW POWER. **THE MAXIMUM PTO RATIO IS 1.3 TO ONE.** THE PUMPS MAXIMUM SPEED **IS 2650-RPM OR ABOUT 2200 ENGINE RPM.** THE PTO SHOULD BE EQUIPPED WITH AN OVER SPEED CUT OUT DEVICE AT **2200 PTO RPM.** DETERMINE THE METHOD OF ENGAGING THE PTO BY CABLE, ELECTRIC AIR, ELECTRIC HYDRO OR LEVER. **MAXIMUM PTO ENGAGEMENT SPEED SHOULD BE UNDER 1000 ENGINE RPM.**
9. THE PTO MUST BE DEDICATED TO THE GENERATOR'S PUMP WITHOUT ANY OTHER ADDITIONAL MECHANICAL OR HYDRAULIC LOADS.
10. AN ELECTRONIC ENGINE SPEED GOVERNOR IS REQUIRED TO REGULATE THE SPEED OF THE ENGINE WHEN THE GENERATOR IS DRAWING LOAD.

3/30/10sh

PTO TORQUE REQUIREMENTS = GENERATOR
HP X 5252 DIVIDED BY PTO RPM

7.5 KW = 17 HP X 5252 @ 800 RPM = 112 FT LBS

7.5 KW = 17 HP X 5252 @ 1000 RPM = 89 FT LBS

7.5 KW = 17 HP X 5252 @ 1500 RPM = 60 FT LBS

10 KW = 23 HP X 5252 @ 800 RPM = 151 FT LBS

10 KW = 23 HP X 5252 @ 1000 RPM = 121 FT LBS

10 KW = 23 HP X 5252 @ 1500 RPM = 81 FT LBS

12 KW = 27 HP X 5252 @ 800 RPM = 177 FT LBS

12 KW = 27 HP X 5252 @ 1000 RPM = 142 FT LBS

12 KW = 27 HP X 5252 @ 1500 RPM = 95 FT LBS

20 KW = 45 HP X 5252 @ 800 RPM = 295 FT LBS

20 KW = 45 HP X 5252 @ 1000 RPM = 236 FT LBS

20 KW = 45 HP X 5252 @ 1500 RPM = 157 FT LBS

15 KW/3P = 34 HP X 5252 @ 800 RPM = 224 FT LBS

15 KW/3P = 34 HP X 5252 @ 1000 RPM = 178 FT LBS

15 KW/3P = 34 HP X 5252 @ 1500 RPM = 120 FT LBS

HOSES

- PRESSURE HOSE:** WE RECOMMEND AN SAE 100R17 TYPE HOSE WITH MINIMUM PRESSURE REQUIREMENTS OF 3500 PSI.
- LOAD SENSING HOSE:** WE RECOMMEND AN SAE 100R17 TYPE HOSE WITH MINIMUM PRESSURE REQUIREMENTS OF 3500 PSI.
- SUCTION HOSE:** WE RECOMMEND AN SAE 100R4 TYPE HOSE. THIS HOSE MUST BE A “WIRE ENFORCED” SUCTION HOSE WITH A MINIMUM PRESSURE OF 250PSI.
- CASE DRAIN HOSE:** WE RECOMMEND AN SAE 100R4 TYPE HOSE.

RECOMMENDATIONS

- MOUNT THE UNIT AT LEAST 12” ABOVE THE PUMP.
- BE SURE TO CLAMP YOUR HOSES TO CHASSIS.
- DO NOT PULL HOSES TOO TIGHTLY. THEY TEND TO FLEX UNDER PRESSURE.
- NEVER USE 90° FITTINGS AT THE PUMP. USE SWEEPING ELBOWS WHENEVER YOU MAKE BENDS. DO NOT LOOP ANY HOSES.
- BE SURE YOUR HOSES ARE CLEAN. IF POSSIBLE, RUN A PLUG THROUGH AND CAP UNTIL READY FOR USE.
- WHEN FILLING UNIT WITH HYDRAULIC OIL, USE AN OIL FILTER. OIL DIRECT FROM A DRUM IS NORMALLY DIRTY.
- UNIT HOLDS 5 GALLONS OF HYDRAULIC FLUID PLUS WHATEVER IS NEEDED TO FILL HOSES, PUMP AND COOLER.
- WE RECOMMEND MERCON / DEXRON III OR EQUIVALENT HYDRAULIC FLUID.

**FIRE-POWER SELF CONTAINED MODIFIED
CLOSED LOOP ELECTRO-HYDRAULIC
SCHEMATIC DIAGRAM**

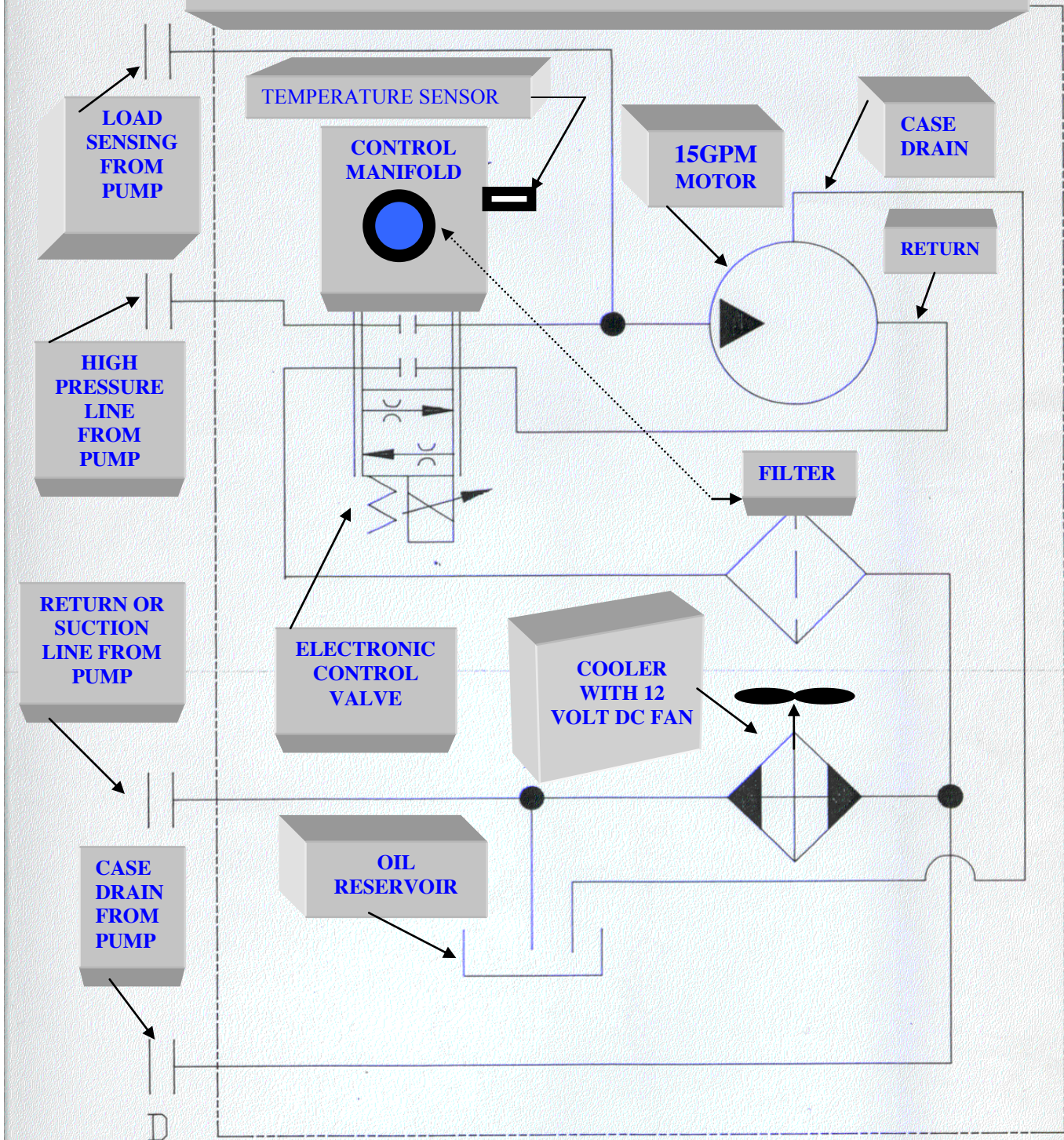

12 & 14 KSC
15KW 3PH
3/30/10 sh

SECTION # 3

AC AND DC ELECTRICAL HOOK-UP AND WIRING DIAGRAMS

12, 14, 20KW SINGLE PHASE AND 15 KW THREE PHASE SELF CONTAINED GENERATORS

HYDRAULIC HOOK-UP DIAGRAM FROM FIRE-POWER UNIT TO PUMP FOR 12, 14, 20 & 15 KW UNITS

TOP VIEW

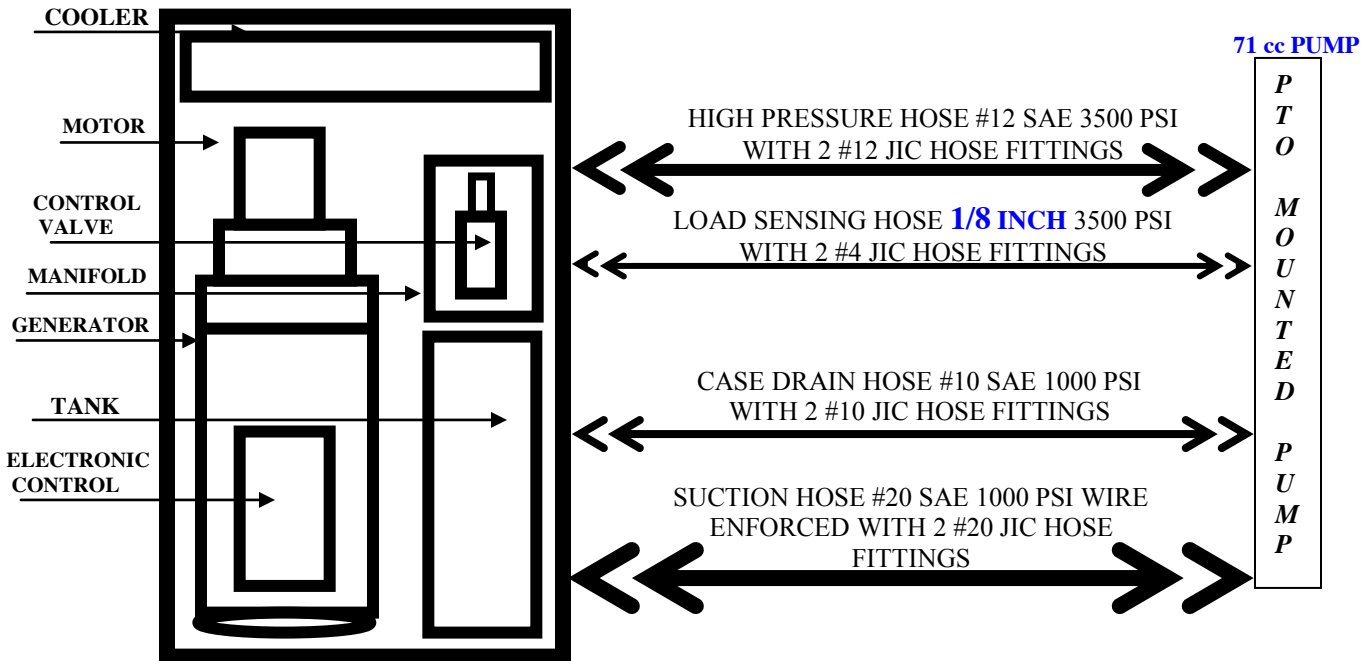

ADAPTER FITTINGS FOR GENERATOR

- MANIFOLD LOAD SENSE # 6 SAE / # 4 JIC
- MANIFOLD HIGH PRESSURE # 12 SAE / # 12 JIC
- TANK CASE DRAIN # 10 SAE / # 10 JIC
- TANK SUCTION # 20 SAE / # 20 JIC

NOTE: THE LOAD SENSING SYSTEM IS FACTORY CALIBRATED FOR A 1/8 INCH DIAMETER 12 FOOT HOSE @ 3500 PSI SUPPLIED WITH THE SYSTEM. IF THE HOSE IS TO LONG COIL AND SECURE IT NEATLY. IF YOU REQUIRE A LONGER LINE CONTACT THE FACTORY

REV-4/19/10 SH

ADAPTER FITTINGS FOR PUMP

- # 4 SAE / # 4 JIC, LOAD SENSE (1/8 HOSE)
- # 16 SFO CODE 61 FLANGE / # 12 JIC
- # 10 SAE / #10 JIC
- # 32 SFO CODE 61 FLANGE / # 20 JIC

15 KW THREE PHASE GENERATOR OVERVIEW ELECTRICAL HOOK-UP AC AND DC

TOP VIEW

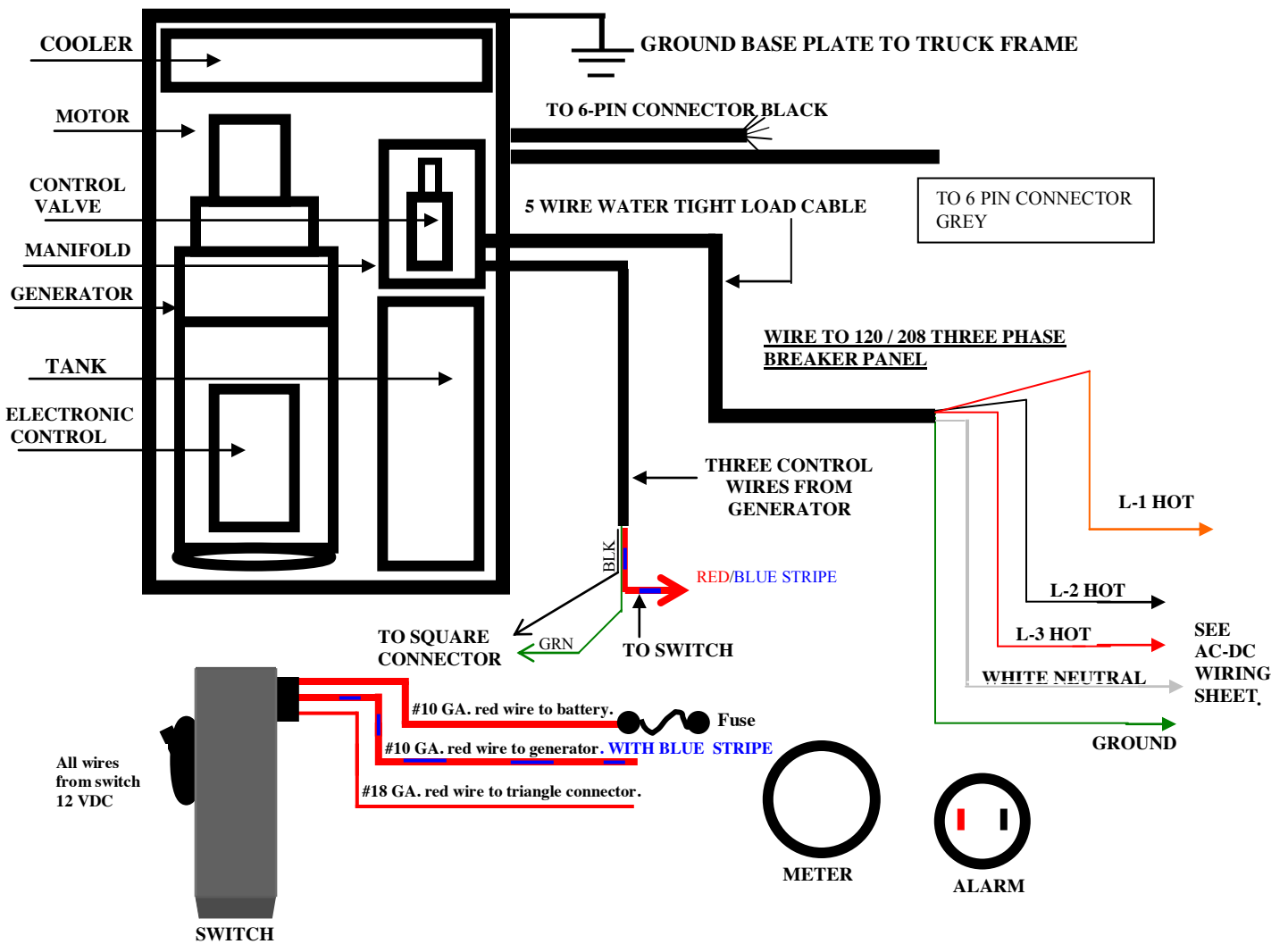

GENERATOR AC-DC WIRING INSTRUCTIONS

1. REMOVE TOP COVER FROM THE PRE-WIRED SWITCH (SUPPLIED). MOUNT GENERATOR ON OFF SWITCH BOX ON THE CONTROL PANEL UNDER OR NEXT TO THE DIGITAL DISPLAY METER. MOUNT THE HIGH TEMP OIL ALARM UNDER THE GENERATOR ON OFF SWITCH. (SEE NEXT PAGE FOR HOLE SIZES)
2. CONNECT THE #18 GAGE **RED** WIRE FROM THE ON OFF SWITCH TO THE **RED** TAB ON THE HIGH TEMP ALARM. CONNECT THE SECOND #18 GAGE **RED** WIRE TO THE **RED** WIRE ON THE SQUARE CONNECTOR #1 PIN SUPPLIED WITH THE DIGITAL DISPLAY METER. CONNECT THE THIRD 18 GA. **RED** WIRE FROM THE BACK OF THE SWITCH TO THE **RED** WIRE ON THE 3 PIN TRIANGLE CONNECTOR. GROUND THE **BLACK** WIRE FROM THE 3 PIN TRIANGLE CONNECTOR THE WHITE WIRE IS NOT USED. ALLOW ABOUT 6 INCHES FOR A SERVICE LOOP. (SEE INSTRUCTIONS SUPPLIED WITH THE DIGITAL DISPLAY METER)
3. CONNECT THE #18 GAGE **GREEN** AND **BLACK** WIRE FROM THE GENERATOR TO THE **GREEN** AND **BLACK** WIRE ON THE SQUARE 4 WIRE MALE CONNECTOR SUPPLIED WITH THE DIGITAL DISPLAY. CONNECT THE **YELLOW** WIRE FROM THE 4 PIN CONNECTOR TO THE GROUND TERMINAL ON THE ALARM. CONNECT THE # 10 **RED** WIRE WITH BLUE STRIPE FROM THE GENERATOR TO THE (**#10 RED WIRE WITH BLUE STRIPE MARKED TO GENERATOR**) ON THE REAR OF THE ON OFF SWITCH.
4. CONNECT A #10 **RED** WIRE FROM THE REAR OF THE SWITCH DIRECTLY TO THE POSITIVE TERMINAL OF THE 12-VOLT BATTERY USING THE 30 AMP FUSE SUPPLIED. MOUNT THE FUSE AS CLOSE TO THE BATTERY AS POSSIBLE.
5. CONNECT 6 PIN CONNECTOR ON GENERATOR TO METER.
CAUTION: DO NOT TURN SWITCH ON! REMOVE THE FUSE UNTIL THE UNIT IS READY FOR START-UP! (SEE THE DETAILED START-UP INSTRUCTIONS IN THIS MANUAL).

- NOTE:**
- BE SURE OUR GENERATOR BASE PLATE IS GROUNDED TO THE TRUCK FRAME.
 - BE SURE TO HAVE A QUALIFIED ELECTRICIAN MAKE ELECTRICAL CONNECTIONS FROM THE GENERATOR TO THE JUNCTION BOX.

INSTALLATION ...

Before installing the **FROG D-3P**, check to make sure you have the following components. Call the factory if any of the components are missing.

- 1) **Frog D-3P** display module
- 2) Extension cable for power
- 3) 3 - Transformers
- 4) 3 - Current Transformers
- 5) Temperature sender (optional)

MECHANICAL :

Display Module :

Installation for **FROG D-3P** is extremely simple. The control module can be mounted anywhere on the electrical panel. **FROG D-3P** control module has a square flange with overall dimensions of 4.25" X 4.25" . A cutout hole of 3.75" in diameter is required. To ensure proper installation, follow these procedures carefully:

- 1) Locate a suitable position on the electrical panel
- 2) Locate the center of the cutout hole and make a 3.75" diameter cutout.
- 3) Insert the **FROG D-3P** control module into the cutout hole and locate the four 10-32 mounting screw holes on the four corners of the flange.
- 4) The dimensions for locating the cutout hole and the mounting holes can be found in Figure 2.

Current Transformers :

3 current transformers are supplied with the **FROG D-3P**. All 3 current transformers are identical and they can be used either to measure line 1, line 2, or line 3 current draw. Install the current transformers before the circuit breaker; one wire through each current sensor. Refer to Figure 4 for wiring information.

Voltage Transformers :

The 3 voltage transformers supplied will work for both 110V and 220V systems. Refer to Figure 5\6 for wiring information.

Option ...

Engine oil temperature sensor

The engine oil temperature sensor has a 1/8 NPT male threads. This sensor can be easily screwed into the engine oil pan.

ELECTRICAL WIRING:

Wiring for the **FROG D-3P** system is very simple. All extension cables are supplied with connectors to simplify the interconnections. For complete wiring diagram, refer to Figure 1.

What to connect?

1) Use the extension cable supplied, provide 12VDC and ground to the electronic module. Supply 12 VDC to the RED wire and ground to the BLACK wire.

2) The **FROG D-3P** is supplied with 3 current transformers. Each phase wire has to go through the center of the current transformer. Connect the white and the black wires from the current transformer to the 6 pin Deutsch connector behind the **FROD D-3P** module. Refer to Figure 1 for proper wire connection.

3) Connect the AC output (before the main circuit breaker) from the generator to the voltage transformer. The standard transformer supplied is for 120/240 vac input. Connect one of the phase and the neutral wire for star winding (Or between two phase for delta winding of the generator)to the primary input of the transformer. Connect the output (secondary coil) of the transformer to the **FROG D-3P** module. (Do not use the center tap wire. The center tap wire is normally jumped at the factory. Use one transformer for each phase. Refer to Figure 1 for the proper color of the wire and pin number.

Optional installation ...

4) An optional buzzer can be connected for the audio alarm. (Buzzer is optional) Refer to Figure 1 for proper wiring of the buzzer.

5) **FROG D-3P** is also capable of monitoring the engine oil temperature. (Sensor not supplied. Can be purchased as an option.) There are 3 wires from the sensor; red , black, and green. All 3 wires have to be connected. Refer to Figure 1 for wiring connection.

Changing the Rated capacity setting on the FROG D-3P

Each **FROG D-3P** is set up to work on a customer specified generator rating. The over current rating warning will not work properly if the proper generator rating is not selected. Check the label behind the module to ensure that it is set up for the correct generator rating. If you need to use the **FROG D-3P** on a generator with a different rating, you will need to disassemble the unit to change the dip switch settings on the main processor board.

How to access the Dip Switch

- 1) Loosen the two set-screws located on the left and right sides of the front plate.
- 2) Turn the unit over so that it faces down, and while holding the cylindrical can, tap the edges of the front plate with a rubber mallet until it comes off.
- 3) The dip switch may be red or blue.
- 4) Be aware that the ON position may be downward, depending on how you are holding the unit. The word "ON" is marked on the switch in the proper orientation.
- 5) Set switches 1 through 4 (they are labeled) as below.

Back of FROG D-3P front plate

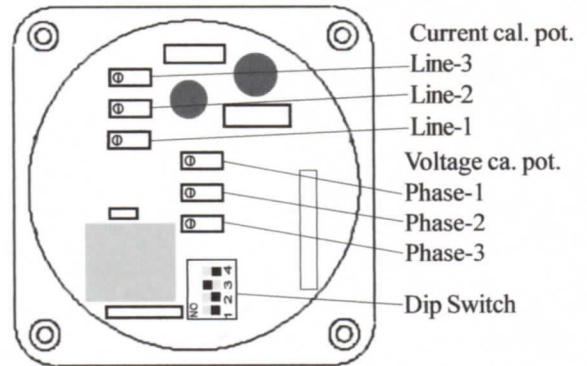

How to set the rated capacity :

The selection of generator capacity can be done by using the 4 positions dip switch located on the processor board.

Generator Rating (KW)	Dip Switch			
	4	3	2	1
10	ON	ON	ON	ON
15	ON	ON	ON	OFF
20	ON	ON	OFF	ON
25	ON	ON	OFF	OFF
30	ON	OFF	ON	ON
35	ON	OFF	ON	OFF
40	ON	OFF	OFF	ON
45	ON	OFF	OFF	OFF
50	OFF	ON	ON	ON
55	OFF	ON	ON	OFF
60	OFF	ON	OFF	ON
65	OFF	ON	OFF	OFF
70	OFF	OFF	ON	ON

Generator Display Module

Display Specifications

- Frequency : 0 - 99.9 Hz
- Amp 1, Amp 2, and Amp 3 : 0 - 150 Amps
- AC Voltage : 0 - 300 VAC
- Oil Temperature : 0 deg. F to 230 deg. F
- Hourmeter : 0 - 9999 Hours in 1 hour increment



Operations with the "Mode" button :

The mode switch allows the user to read the operational hours on the generator and the current engine oil temperature. The first time the "MODE" button is pressed, the **FROG-D-3P** will display the generator hours as follows:

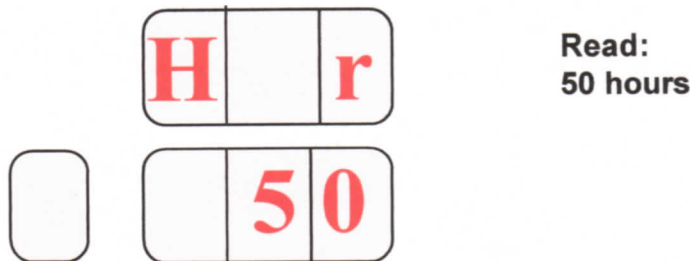

Pressing the "MODE" button again will switch the display to show the engine oil temperature:



Pressing the "MODE" switch again will return the display to the normal display mode.

LINE

Operations with the "LINE" button :

The 'LINE' button allows the operator to read the individual line voltage and current draw. There are 7 selections for the 'LINE' button. These selections are shown in the diagram below.

DISPLAY SELECTIONS

- 1) A-N = Phase A to neutral
- 2) B-N = Phase B to neutral
- 3) C-N = Phase C to neutral
- 4) A-B = Phase A to Phase B
- 5) B-C = Phase B to Phase C
- 6) C-A = Phase C to Phase A
- 7) Auto = Automatically scroll from 1 to 6

NOTE:

- 1) A = Current draw on line A
- 2) B = Current draw on line B
- 3) C = Current draw on line C

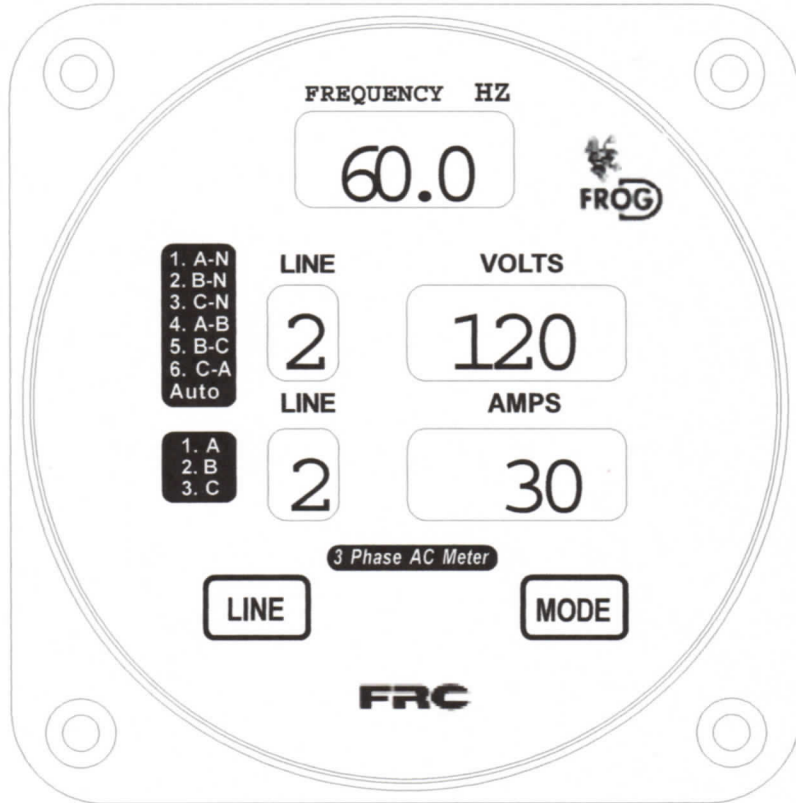

When the **Frog D-3P** is turned on, the 'LINE' display mode will be set to 'Auto'. In 'Auto' mode, the display will scroll continuously through all the parameters. If you need to read the voltage and current draw for a specific line, press and hold the 'LINE' button until the number corresponding to the desired selection shows in the LINE window. The larger displays will then show the desired readings. Leave the display in 'Auto' during normal operations so that you can monitor all the parameters.

note: When displaying the readings for Lines 4, 5, or 6, the AMPS display will not display a number, but will show '----' instead as depicted at right:



ELECTRICAL WIRING

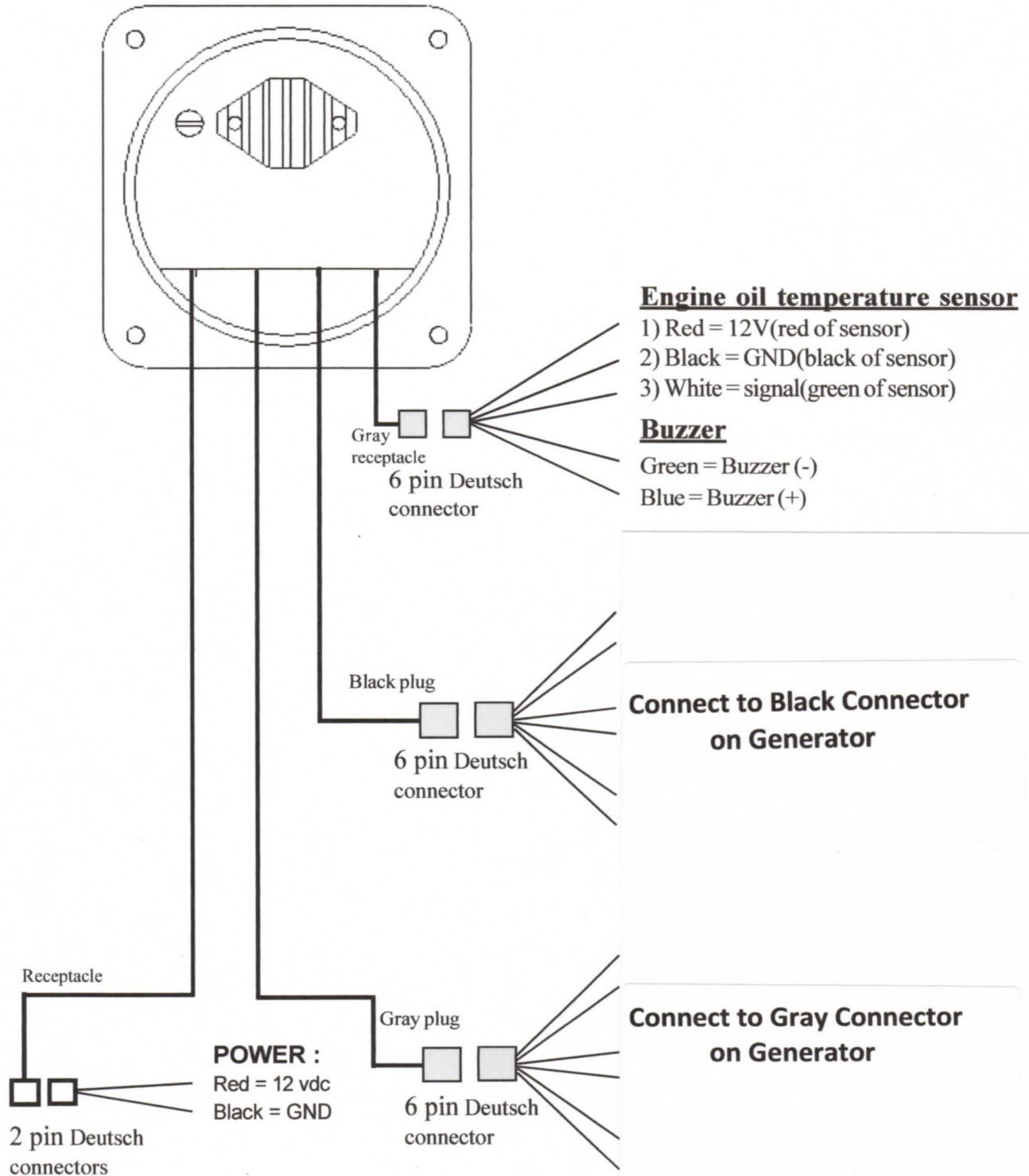

F
P

Figure 1

DIMENSIONS

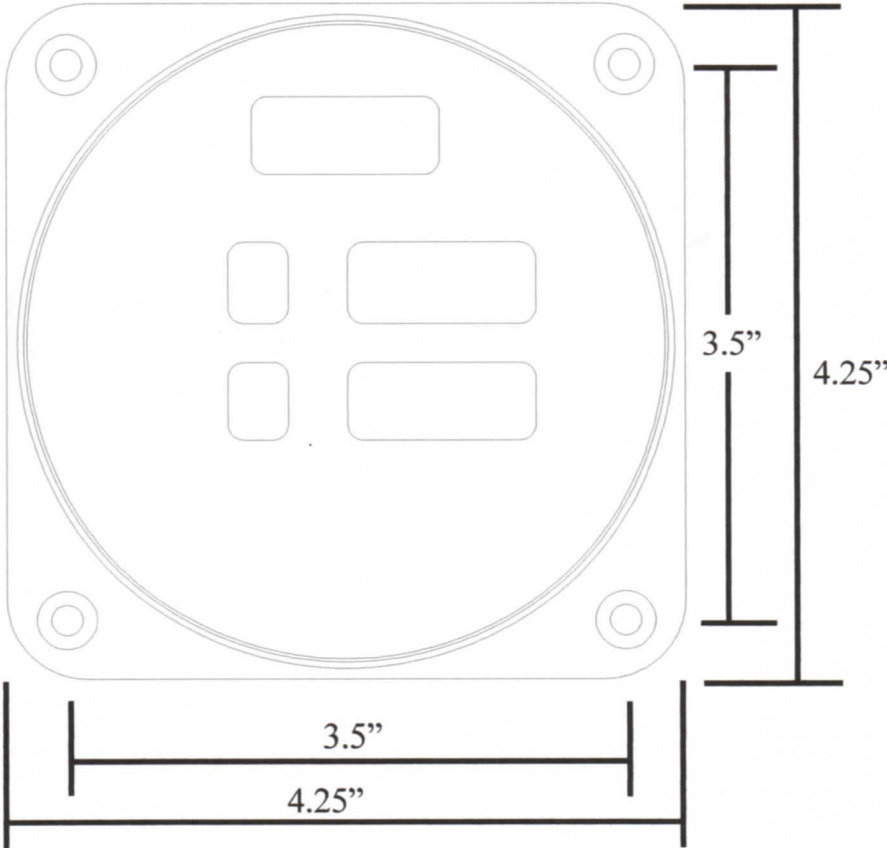
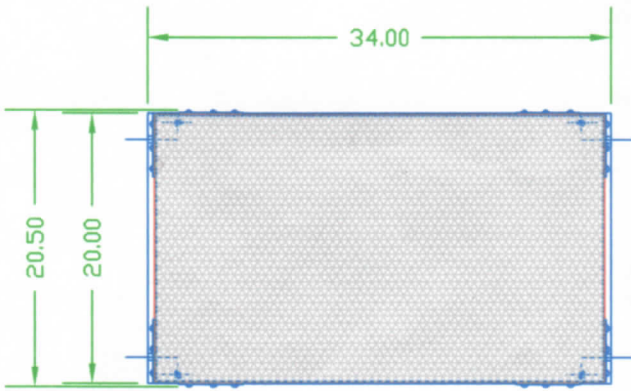

Figure 2

SECTION # 4

MECHANICAL DRAWINGS MOUNTING TEMPLATE INSTALLATION AND START-UP



TOP VIEW

#	PART #	DESCRIPTION
1	572461	GENERATOR 7.5 KW
1A	572352A	GENERATOR 10 KW
1B	572352B	GENERATOR 12 KW
2	572393	RESERVOIR / TANK
3	572503	RESERVOIR CAP
4	572399	COOLER
5	572467	HYDRAULIC MOTOR 7.5 KW
5A	572362	HYDRAULIC MOTOR 10 KW
5B	572362	HYDRAULIC MOTOR 12 KW
6	572390	FILTER
7	572391	HYDRAULIC CONTROL VALVE
8	572394	MANIFOLD
9	572435	C.P.U.
10	572502	CAGE MESH
11	572462	CAGE FRAME - RED
11A	572389	CAGE FRAME - YELLOW
12	572434	DIAMOND PLATE TOP

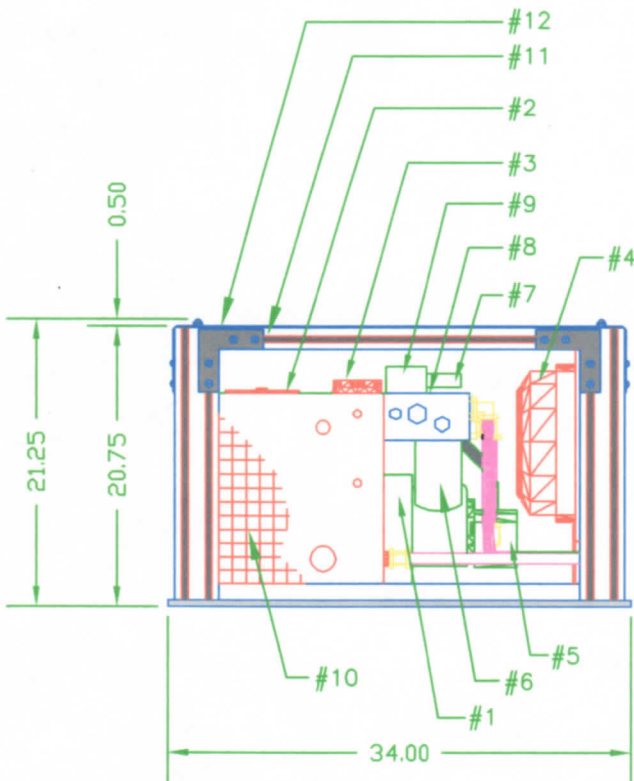

FRONT VIEW

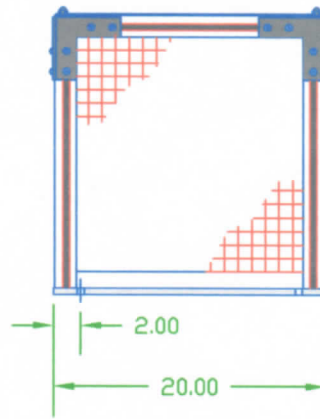

SIDE VIEW

FABCO GENERATOR'S INC.

1570 KINGS HIGHWAY
CHESTER, NY 10918

PRODUCT: HYDRAULIC GENERATOR

MODEL NO. ALL SELF CONTAINED UNITS

DESIGNED BY:
R.F.

APPROVED BY:
R.F.

DRAWN BY:
T.M.

DRAWING #:

DATE:
10/1/02

PROJECT #:

SCALE:
AS SHOWN

572500

PAGE OF

INSTALLATION AND START-UP PROCEDURE

***BE SURE PUMP ROTATION AND PTO ROTATION IS CORRECT, SEE PUMP SPEC IN THIS MANUAL. RIGHT OR CW PUMPS ARE COMMON, LEFT OR CCW ARE NOT. THE PTO SHOULD ROTATE IN THE OPPOSITE DIRECTION OF THE PUMP. THE GENERATOR SHOULD BE MOUNTED AT LEAST 1 FOOT HIGHER THAN THE PUMP. DO NOT MOUNT GENERATOR CLOSER THAN 3 FEET FROM A RADIO ANTENNA. USE A MINIMUM SIZE OF 3/8-INCH CASE HARDENED BOLTS TO MOUNT THE GENERATOR TO THE TRUCK BODY.**

MAKE SURE THERE IS PROPER VENTILATION AND AIR CIRCULATION FOR THE SYSTEM. ALLOW AT LEAST (4) INCHES CLEARANCE AT EACH END OF THE GENERATOR FOR THE OIL COOLER AIR DISCHARGE. DO NOT RESTRICT AIR DISCHARGE (LOUVERED DOORS SHOULD NOT BE CONSIDERED PROPER VENTILATION).

CONNECT THE PUMP TO THE PTO. THIS IS EITHER A DIRECT MOUNT OR A DRIVE SHAFT MOUNT. FOR A DRIVE SHAFT MOUNT, BE SURE THE PUMP IS WELL SUPPORTED. ALSO, THE PUMP SHOULD BE ISOLATED FROM THE CHASSIS TO AVOID VIBRATION, NOISE, OR POSSIBLE DAMAGE TO THE PUMP.

ALWAYS POSITION THE PUMP WITH CASE DRAIN ON TOP OR 45 DEGREES EITHER SIDE FROM TOP CENTER. FAILURE WILL OCCUR IF CASE DRAIN IS NOT POSITIONED WITHIN 45 DEGREES FROM THE LEFT OR RIGHT SIDE OF TOP CENTER. CONNECT THE 4 HYDRAULIC HOSES TO THE GENERATOR AND PUMP.

REMOVE THE DIAMOND PLATE TOP COVER **FILL CASE DRAIN HOSE FROM THE GENERATOR END TO PRIME THE PUMP WITH FILTERED DEXRON III HYDRAULIC OIL FIRST.** RE-CONNECT HOSES AND THEN FILL THE TANK WITH 10 MICRON FILTERED DEXRON III OIL. (THE HYDRAULIC OIL FROM QUARTS AND DRUMS ARE NOT CLEAN ENOUGH)

INSERT THE 30 AMP 12-VOLT DC FUSE **WITH START SWITCH IN THE OFF POSITION.** ENGAGE PTO WITH THE ENGINE RUNNING IDLE TURN START SWITCH TO THE ON POSITION; CHECK THE DIGITAL METER FOR VOLTAGE AND FREQUENCY DISPLAY. **LET THE UNIT RUN FOR LESS THAN 5 MINUTES** CHECK FOR LEAKS. YOU WILL HEAR SOME LOW NOISES FROM PUMP AND MOTOR WHILE THE AIR IS PURGING OUT FROM THE SYSTEM.

TOP-OFF TANK AND RE-START, SET ENGINE GOVERNOR AT OPERATING SPEED. APPLY LOAD IN SMALL STEPS UNTIL FULL OPERATING LOAD IS REACHED. CHECK FOR LEAKS, NOISE AND OIL LEVEL, LET UNIT RUN AT LOAD FOR ABOUT ½ HOUR. RE-CHECK OIL LEVEL. NOW THE FIRE-POWER GENERATOR IS READY FOR OPERATION. REPLACE THE DIAMOND PLATE TOP COVER.

SECTION # 5

MAINTENANCE, TROUBLE SHOOTING, MAINTENANCE LOG & TEST REPORTS

SYSTEM MAINTENANCE

THERE IS LITTLE MAINTENANCE REQUIRED WITH A FIRE-POWER GENERATOR. IT CONSISTS PRIMARILY OF CHANGING THE OIL AND FILTER AND PERFORMING A VISUAL INSPECTION OF THE ENTIRE GENERATOR SYSTEM. WITH A LITTLE MAINTENANCE AND PROPER INSTALLATION, THE SYSTEM SHOULD OPERATE TROUBLE FREE FOR 15 YEARS OR MORE.

THE HYDRAULIC FLUID AND THE FILTER SHOULD BE CHANGED EVERY 1,000 HOURS OR 5 YEARS, WHICHEVER OCCURS FIRST OR IF THE HYDRAULIC OIL BECOMES DISCOLORED, BURNT SMELLING OR BECOMES ABRASIVE TO THE TOUCH. ANY OF THESE CONDITIONS ARE AN INDICATION OF A SYSTEM PROBLEM AND STEPS SHOULD BE TAKEN TO DIAGNOSE THEM.

DRAIN OIL FROM THE TANK BY REMOVING THE LARGE SUCTION LINE FROM THE PUMP. CAP THE HOSE END, UNSCREW THE FILTER AND **(REPLACE WITH THE SAME TYPE)** FILL THE NEW FILTER WITH CLEAN HYDRAULIC FLUID AND SCREW IT TO THE FILTER HEAD. RE-CONNECT SUCTION LINE AND RE-FILL THE TANK WITH FILTERED OIL. RE-START THE SYSTEM AND RUN THE ENGINE IDLE WITH NO LOAD APPLIED TO THE GENERATOR UNDER FIVE MINUTES TO PURGE ANY AIR OUT OF THE SYSTEM. SHUT UNIT DOWN AND TOP OFF THE TANK BEFORE RESUMING NORMAL OPERATION.

ENTER OIL AND FILTER CHANGE IN THE MAINTENANCE LOG PROVIDED ON THE LAST PAGES CONTAINED IN THIS MANUAL.

VISUALLY INSPECT THE ELECTRICAL WIRING **FOR CORROSION AND LOOSE OR BAD CONNECTIONS.**

MAKE SURE THAT THE GENERATOR HAS NOT BECOME SEVERELY CONTAMINATED WITH MUD OR GREASY SOIL BUILDUP. THIS COULD CONSTRICT AIRFLOW AND CAUSE PREMATURE GENERATOR FAILURE. USE AN AIR-HOSE AND BLOW OUT THE HEAT EXCHANGER FINS AND THE INSIDE OF THE GENERATOR IF THERE IS BUILDUP OF DIRT OR OTHER CONTAMINATES. **DO NOT USE WATER TO CLEAN THE INSIDE OF THE GENERATOR.**

IF THE GENERATOR HAS BECOME SUBMERGED IN WATER, THE WINDINGS **MUST** BE AIR DRIED BEFORE REUSING.

CHECK THE FITTINGS FOR LOOSE CONNECTIONS OR ANY LEAKS. INSPECT HOSES FOR BULGES, CHAFFING, OR DAMAGE. REPLACE IMMEDIATELY IF DEFECTS ARE FOUND.

CHECK THAT THE PUMP IS SECURELY MOUNTED TO THE PTO OR DRIVE SHAFT. ENSURE THAT THERE ARE NO LEAKS FROM THE FITTINGS OR THE FRONT SEAL. A LEAK AT THE FRONT SEAL WILL POSSIBLY INDICATE A BAD ALIGNMENT OR THE NEED FOR VIBRATION ISOLATORS. IF THE LEAK AT THE FRONT SEAL IS CAUGHT EARLY ENOUGH AND THE PROBLEM IS CORRECTED, IT CAN ELIMINATE EXPENSIVE REPAIRS AND DOWN TIME.

TROUBLE SHOOTING

SYMPTOM

POSSIBLE CAUSE

GENERATOR DOES NOT START	CHECK 12 VOLT 30 AMP INLINE DC FUSE CHECK FOR LOOSE OR BROKEN WIRES TURN START SWITCH OFF, WAIT 10 SECONDS AND TURN SWITCH ON. (THIS RESETS THE SYSTEM)
OIL TEMP ALARM ACTIVATES	CHECK HYDRAULIC FLUID LEVEL IN TANK CHECK HOSES AND FITTINGS FOR LEAKS CHECK HOSES FOR CRIMPS CHANGE OIL FILTER CHECK IF COOLING FAN IS RUNNING CHECK FOR AIR FLOW BLOCKAGE
NO VOLTAGE OR AMPS ON METER DISPLAY	CHECK MAIN CIRCUIT BREAKER CHECK FOR LOOSE OR BROKEN WIRES AND CONNECTORS ON METER AND BREAKER PANEL
LOW VOLTAGE OR FREQUENCY	CHECK ENGINE SPEED GOVERNOR
DIGITAL DISPLAY METER DOESN'T LIGHT	CHECK 12 VOLT DC 30 AMP INLINE FUSE CHECK FOR LOOSE OR BROKEN WIRES CONNECTED TO METER
AMPS OR VOLTAGE BLINKS ON AND OFF ON METER DISPLAY REV-4-2/28/05 G. B	REDUCE LOAD, GENERATOR COULD BE OVERLOADED CHECK FOR FRAYED OR BROKEN LOAD WIRES